

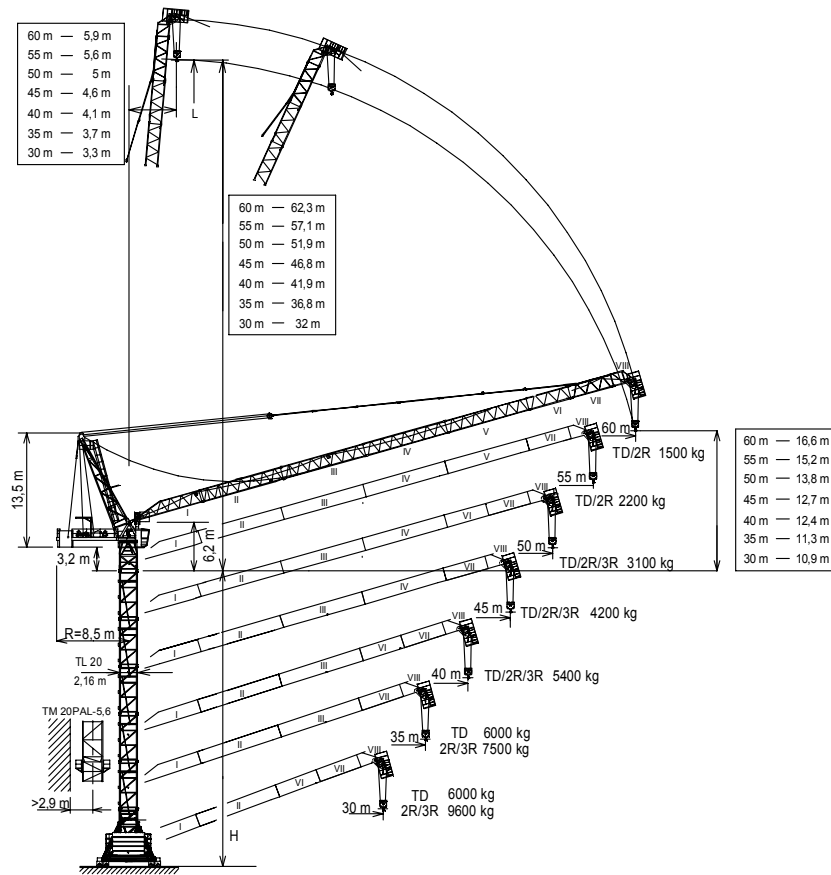

EN 14439
C25

UNE-EN-ISO 9001



Máxima altura de torre sin arriostrar (m). Maximum tower height without fastening (m). Hauteur maximale de tour sans ancrage (m). Максимальная высота башни без крепления (m). Desteksiz maksimum kule yüksekliği (m). أقصى ارتفاع للبرج بدون ربط (م)	H =	*Tramo pluma I / Jib section I / Tronçon de flèche / Секция стрелы / Bom bölümü / أجزاء الذراع	*Tramo pluma II / Jib section II	207.40.000	AL 20	153.21.800
		**Punta de pluma / Jib end / Pointe de flèche / Конец стрелы / Bom ucu / مقدمة الذراع	*Tramo pluma III / Jib section III	207.41.000	AS 20	160.21.010
			*Tramo pluma IV / Jib section IV	207.42.000	ASR 20	160.21.200
			*Tramo pluma V / Jib section V	207.43.000	TL 20	153.31.000
			*Tramo pluma VI / Jib section VI	207.44.500	TL 20-5,6	204.31.400
			*Tramo pluma VII / Jib section VII	207.44.000	TS 20-5,6	204.31.200
			*Tramo pluma VIII / Jib end VIII	207.45.000	TS 20-5,6A	204.31.500
			**Punta pluma VIII / Jib end VIII	207.46.000	TSR 20-5,6	204.31.000
			BLI 6-20-5,6H	166.20.000	TSR 20-5,6A	204.31.300
			BSI 8-20-5,6H	166.20.200	TM 20PAL-5,6	166.35.500
			ABH 100	201.23.000		

(H) TRASLACIÓN / TRAVELLING /
TRANSLATION / ПЕРЕМЕЩЕНИЕ / RAY YÜRÜYÜŞLÜ / متحركة

(H) ESTACIONARIA / STATIONARY /
STATIONAIRE / СТАЦИОНАРНОЕ СОСТОЯНИЕ / SABIT / ثابتة

TD/2R/3R

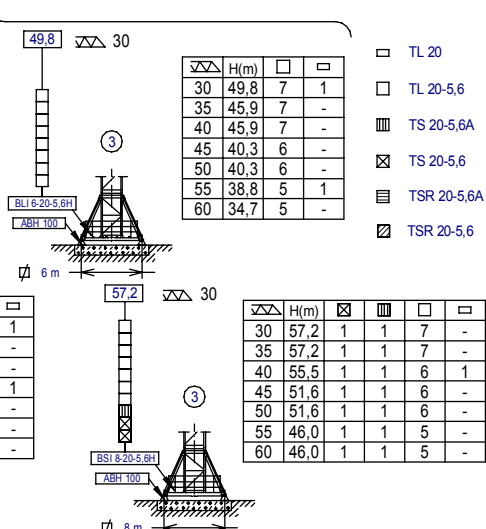
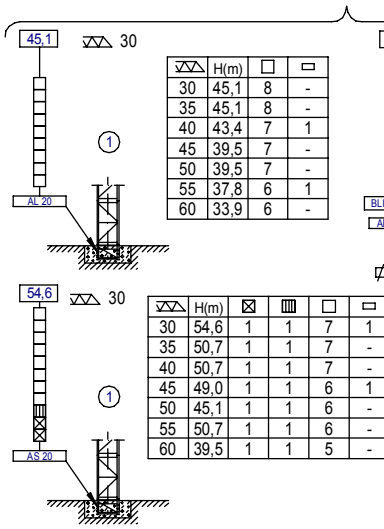
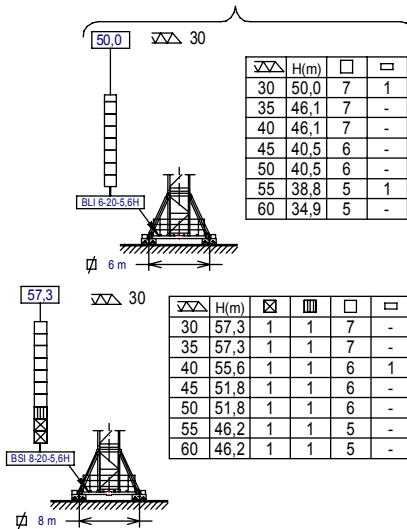

- ☐ TL 20
- ☐ TL 20-5,6
- ☒ TS 20-5,6A
- ☒ TS 20-5,6
- ☒ TSR 20-5,6A
- ☒ TSR 20-5,6









JASO EQUIPOS DE OBRAS Y CONSTRUCCIONES, S.L.





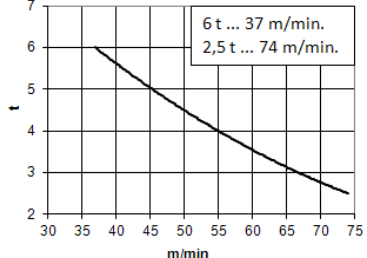
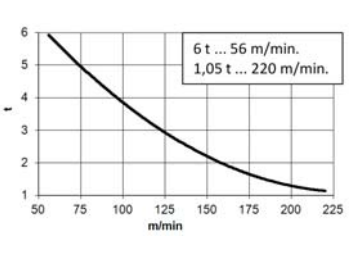
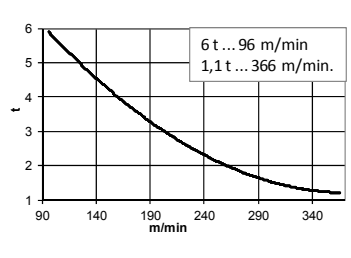

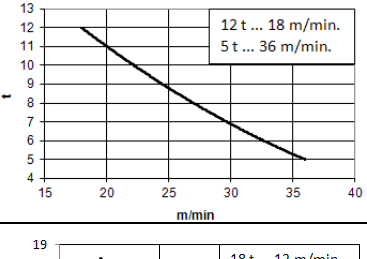
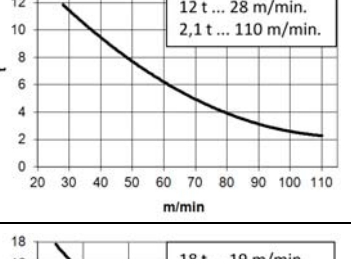
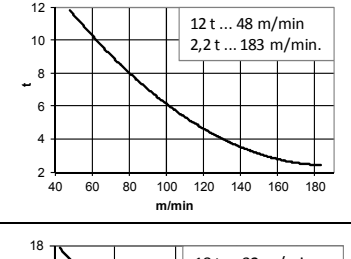
FEM 1005 - C25

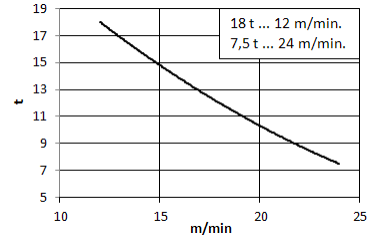
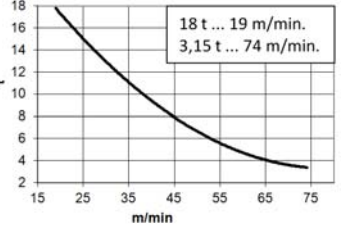
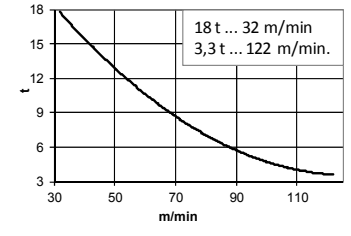
Reservado el derecho a modificaciones sin previo aviso. Declinamos toda responsabilidad derivada de la información proporcionada / Subject to modification, without previous warning. This information is supplied without liability / L'entreprise se réserve le droit de procéder à des modifications sans préavis. Nous déclinons toute responsabilité quant aux informations fournies / Мы оставляем за собой право на внесение изменений без предварительного уведомления. Мы снимаем с себя любую ответственность в отношении предоставленной информации / Önceden bildirilmeksizin değiştirilme hakkı saklıdır. Verilen bilgiler için hiçbir sorumluluk kabul etmemekteyiz / حقوق التغيير محفوظة دون إشعار مسبق. دون أدنى مسؤولية عن المعلومات المقدمة.

TD/2R/3R [t]		Cargas máximas / Maximum loads / Charges maximales / Максимальные нагрузки / Maksimum yük / أقصى حمولة / TD/2R/3R - 6t/12t/18t										TD 6t @...[m]	2R 12t @...[m]	3R 18t @...[m]
Alcance del gancho [m] / Hook reach [m] / Portée du crochet (m) / Радиус действия крюка (m) / Kancanın yüksekliği (m) / مدى الخطاف														
[m]	60	55	50	45	40	35	30	25	20					
60	1,5	2,2	3,0	3,9	5,2	6,6	8,6	11,4	12,0	37,1	24,2			
55	—	2,2	3,0	3,9	5,2	6,6	8,6	11,4	12,0	37,1	24,2			
50	—	—	3,1	4,1	5,3	6,7	8,7	11,5	15,6	37,4	24,3	17,9		
45	—	—	—	4,2	5,4	6,8	8,8	11,5	15,6	37,8	24,3	17,9		
40	—	—	—	—	5,4	6,8	8,8	11,5	15,6	37,8	24,3	17,9		
35	—	—	—	—	—	7,5	9,5	12,2	16,4	35,0	25,4	18,5		
30	—	—	—	—	—	—	9,6	12,3	16,4	30,0	25,5	18,5		

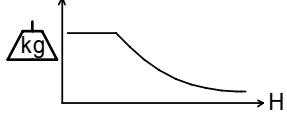
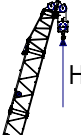
*opcional / *optional / *en option / *опция / *orsiyonel / *اختياري						
EC6074VF 44,1 kW		EC88110VF 65 kW		*EC150185VF 110 kW		
	 <p>6 t ... 37 m/min. 2,5 t ... 74 m/min.</p>	 <p>6 t ... 56 m/min. 1,05 t ... 220 m/min.</p>	 <p>6 t ... 96 m/min. 1,1 t ... 366 m/min.</p>			
	 <p>12 t ... 18 m/min. 5 t ... 36 m/min.</p>	 <p>12 t ... 28 m/min. 2,1 t ... 110 m/min.</p>	 <p>12 t ... 48 m/min. 2,2 t ... 183 m/min.</p>			
	 <p>18 t ... 12 m/min. 7,5 t ... 24 m/min.</p>	 <p>18 t ... 19 m/min. 3,15 t ... 74 m/min.</p>	 <p>18 t ... 32 m/min. 3,3 t ... 122 m/min.</p>			

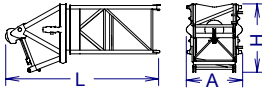
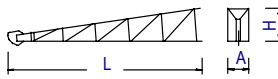
				 400V 50Hz			
TG2020VF 2x7,3 kW	OG1507V 2x5,5 kW	EP6015VF 44,1 kW	TH2006 15 kW	$P_{TOTAL}(EC88110VF + OG1507VF + EP6015VF) = 120,1 \text{ kW}$ $P_{TOTAL}(EC150185VF + OG1507VF + EP6015VF) = 165,1 \text{ kW}$			
0...20 m/min	0...0,2 0,2...0,35 0,35...0,7 r/min sl/min	1,5 min	0,6 m/min		$H \leq$	TD 568m 2R 284m 3R 189m	

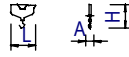
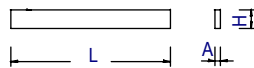
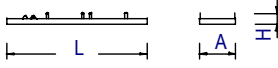
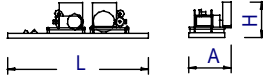
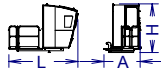
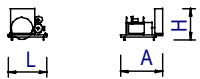
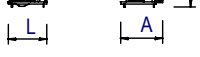
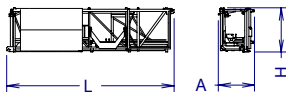
DENOMINACIÓN / DENOMINATION / DÉSIGNATION / НАЗВАНИЕ / AÇIKLAMA / اسم		L [m]	A [m]	H [m]	P / W [kg]	
Torre inferior / Lower tower / Tour inférieure / Нижняя башня Alt kule / البرج السفلي	TLI20-5,6	5,886	2,306	2,357	4235	
	TSI20-5,6	5,966	2,328	2,390	5390	
	TSRI20-5,6	5,990	2,257	2,257	6562	
Torre / Tower / Tour Башня / Kule / برج	TL20	4,175	2,201	2,281	2095	
	TL20-5,6	5,886	2,306	2,357	2938	
	TS20-5,6	5,966	2,328	2,390	3604	
	TSR20-5,6	5,990	2,257	2,257	4262	
	TSR20-5,6A	5,926	2,388	2,325	3637	
	TS20-5,6A	5,978	2,381	2,331	4221	
Torre asiento pista, base punta torre y orientación / Slewing table, tower head base and slewing mechanism / Tour pivot + base du porte-flèche + mécanisme d'orientation / Сиденье площадки + основание верхней секции башни + поворотный механизм / Döner tabla+kule bölümü tabanı+mekanizma برج وحدة الدوران + قاعدة رأس البرج + آلية الدوران			6,970	2,550	3,057	9500
Estructura punta de torre sin base / Tower head structure without base / Structure de porte-flèche sans base / Структура верхней секции башни без основания / Tabansız kule başının yapısı هيكل رأس البرج بدون قاعدة			11,58	1,910	2,033	5470
Tramo de pluma / Jib section / Tronçon de flèche / Секция стрелы / Bom bölümü / أجزاء الذراع	(I)	9,180	2,040	1,765	1585	
	(II)	10,160	1,266	1,565	1410	
	(III)	10,160	1,266	1,565	1340	
	(IV)	10,160	1,266	1,565	1190	
	(V)	10,160	1,266	1,565	1000	
	(VI)	5,270	1,266	1,565	580	
	(VII)	5,270	1,266	1,610	770	
Punta de pluma / Jib end / Pointe de flèche / Конец стрелы / Bom ucu / مقدمة الذراع			3,420	1,560	3,585	856
Polipasto / Hook assembly / Palan / Попуснаст / Kanca takımı / بكرة			0,910	0,350	1,370	455
Tirante sostén pluma / Jib support tie / Tirant de fleche / Растяжка поддержки стрелы / Kol destek bağları / مشد دعامة الذراع			5,000	0,360	0,450	1232
Estructura contrapluma / Counterjib structure / Structure de contre-flèche / Структура противовесной консоли / Denge kolunun yapısı هيكل الذراع المعاكس			7,110	1,875	0,540	1145
Contrapluma con mecanismos / Counterjib with mechanisms / Contre-flèche avec mécanismes / Противовесная консоль с механизмами / Mekanizmalı denge kolu الذراع المعاكس مع الآليات			7,110	2,230	1,819	9200
Plataforma y cabina / Platform and cabin / Plateforme et cabine / Платформа и кабина / Platform ve kabin / منصة وكابينة			3,440	1,810	2,416	856
Mecanismos / Mechanisms / Mécanismes de / Механизмы / Mekanizmalar / آليات كهربائية	Elevación carga / Hoisting / levage de charge / Подъем груза / Yük kaldırma / رافع الحمولة		1,919	2,110	1,540	3830
	Elevación pluma / Luffing / Relevage de flèche / Подъем стрелы / Yük kaldırma ve indirme / رافع الذراع		1,948	2,170	1,400	3250
Transporte torre de montaje/ Jacking cage transport / Transport de tour de montage / Транспортировка монтажной башни / Kaldırma kafesinin taşınması / نقل برج التركيب		TM 20PAL-5,6 	9,550	2,070	2,520	5,690

Section	Height (m)	Cumulative Height (m)	Section	Height (m)	Cumulative Height (m)
1	4.2	4.2	1	5.9	10.1
2	9.8	14.0	2	5.9	16.0
3	15.4	29.4	3	5.9	21.9
4	21.0	50.4	4	5.9	27.8
5	26.6	77.0	5	5.9	33.7
6	32.2	109.2	6	5.9	39.6
7	37.8	147.0	7	5.9	45.5
8	43.4	190.4	8	5.9	51.4
9	49	239.4	9	5.9	57.3
10	54.6	294.0	10	5.9	63.2
11	60.2	354.2	11	5.9	69.1
12	65.8	420.0	12	5.9	75.0

T: Torre / Tower / Tour / Башни / Kuleler / أبراج
 H: Altura / Height / Hauteur / Высота / Yükseklik / ارتفاع

Otras configuraciones de torre / Other tower configuration / Autres configurations / Прочие конфигурации / Diğer konfigürasyonlar / مكونات أخرى

Transporte / Transport / Transport / Транспортировка / Taşıma / نقل

H=33,9 + AL20

7x HIGH CUBE 40'

1x FLAT RACK 40'

Ancho 2,4m wide

TREPADO / CLIMBING / TÉLESCOPAGE / ЛЕСТНИЦА / TIRMANMA / التسلق **J208PA**

$h_{max} = TS\ 20-5,6T + 2 \times TS\ 20-5,6 + TS\ 20-5,6A + 3 \times TL\ 20-5,6$

h (m)	39,2
D (m)	15,6 - 19
P (KN)	1025 / 905
Rmax (KN)	247 / 498

H < 250 m

Trepado interno / Internal climbing. / Télescopage intérieur / Внутренняя лестница / Bina içi tirmanma / التسلق الداخلي

Viento fuera de servicio / Out of service wind / Vitesse du vent hors service / Ветровая нагрузка в покое / Rüzgar devre dışı / الريح خارج الخدمة

Consultar / Consult / Nous consulter / Консультируйтесь / Danışınız / الرجوع إلى

En servicio / In service / En service / В работе / Devrede / في الخدمة

Fuera de servicio / Out of service / Hors service / В покое / Devre dışı / خارج الخدمة

Fecha / Date: 30-09-2013

JASO EQUIPOS DE OBRAS Y CONSTRUCCIONES, S.L.

Ctra./Rd. Madrid - Irún Km. 415
 20.213 IDIAZABAL [Gipuzkoa]
 ESPAÑA / SPAIN
 P.O. Box, 23 - 20.200 BEASAIN

Tel. +34 943 - 18 70 00
 Fax. +34 943 - 18 70 20
 E-mail: jaso@jaso.com
 http://www.jaso.com

FEM 1005 - C25

DELEGACION / DELEGATION

Reservado el derecho a modificaciones sin previo aviso. Declinamos toda responsabilidad derivada de la información proporcionada / Subject to modification, without previous warning. This information is supplied without liability / L'entreprise se réserve le droit de procéder à des modifications sans préavis. Nous déclinons toute responsabilité quant aux informations fournies / Мы оставляем за собой право на внесение изменений без предварительного уведомления. Мы снимаем с себя любую ответственность в отношении предоставленной информации / Önceden bildirilmeksizin değiştirilme hakkı saklıdır. Verilen bilgiler için hiçbir sorumluluk kabul etmemekteyiz / حقوق التغيير محفوظة دون إشعار مسبق. دون إذن مسبق ولية عن المعلومات المقدمة