

$$H_{DR} = H_{SR} - 0,9$$

$H_{SR} =$   
 Altura máxima bajo gancho sin arriostrar (m).  
 Maximum height under hook without fastening (m).  
 Hauteur maximale sous crochet sans ancrage (m).  
 Максимальная высота под крюком без крепления (m).  
 Bağlantısız maksimum kanca altı yüksekliği (m).  
 أقصى ارتفاع تحت الخطاف بدون ربط

C3-17	153.50.500	BRI 10-24	156.20.500
C1-17	142.50.900	TM20L-5,6	166.35.000
P17-10R	153.40.500	TL20	153.31.000
P17-2R	153.41.600	TL20-5,6	204.31.400
P17-3N	142.42.500	TS20-5,6A	204.31.500
P17-4N	142.43.500	TS20-5,6	204.31.200
P17-5N	142.44.500	TSR20-5,6A	204.31.300
P17-6N	153.45.000	TSR20-5,6	204.31.000
P17-7N	153.46.000	TR24/TS20	156.36.800
P17-8N	142.46.500	TR24-5,6	156.30.700
P17-9N	142.48.500	TRD24-5,6	156.30.300
BLI 6-20-5,6H	166.20.000	ABH 100	201.23.000
BSI 8-20-5,6H	166.20.200	ABH 100B	204.23.000
BSRI 8-20-5,6H	166.20.500		

(H) TRASLACIÓN / TRAVELLING /

TRASLATION / ПЕРЕМЕЩЕНИЕ / RAY YÜRÜYÜŞLÜ / متحركة

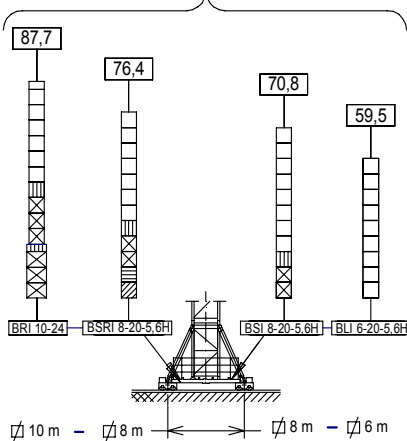

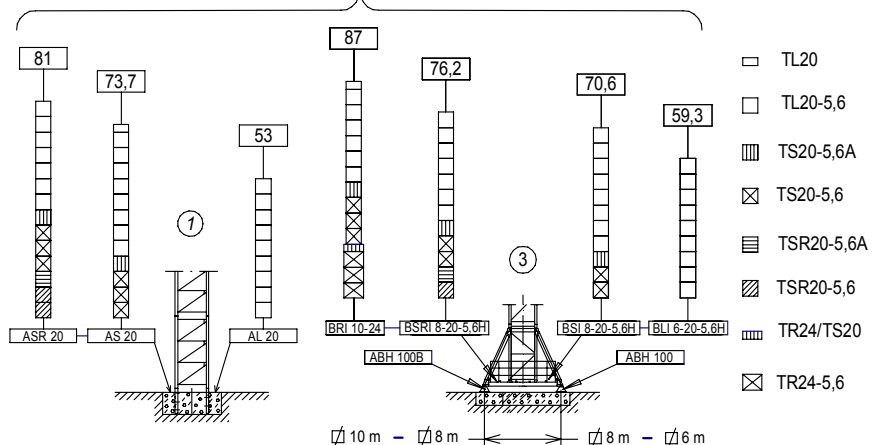

(H) ESTACIONARIA / STATIONARY /

STATIONAIRE / СТАЦИОНАРНОЕ СОСТОЯНИЕ / САБИТ / ثابتة













- TL20
- TL20-5,6
- ▨ TS20-5,6A
- ⊠ TS20-5,6
- ▨ TSR20-5,6A
- ▨ TSR20-5,6
- ▨ TR24/TS20
- ⊠ TR24-5,6

	SR (kg)	Cargas máximas / Maximum loads / Charges maximales / Максимальные нагрузки / Maksimum yük / أقصى حمولة SR-12.000 kg											12000 kg @ ... (m)
	Alcance del gancho [m] / Hook reach [m] / Portée du crochet (m) / Радиус действия крюка (m) / Kancanın yüksekliği (m) / مدى الخطاف												
[m]	75	70	65	60	55	50	45	40	35	30	25	20	
75 m	2500	2748	3034	3368	3762	4235	4813	5536	6466	7705	9440	12000	20,1
70 m	—	3000	3305	3662	4083	4588	5206	5978	6970	8293	10146	12000	21,4
65 m	—	—	3500	3873	4313	4841	5487	6294	7331	8715	10652	12000	22,4
60 m	—	—	—	4200	4670	5234	5923	6785	7893	9370	11438	12000	23,9
55 m	—	—	—	—	5000	5597	6327	7239	8411	9975	12000	12000	25,3
50 m	—	—	—	—	—	5800	6552	7493	8701	10313	12000	12000	26,1
45 m	—	—	—	—	—	—	6800	7771	9020	10685	12000	12000	27,0
40 m	—	—	—	—	—	—	—	7800	9053	10723	12000	12000	27,0
35 m	—	—	—	—	—	—	—	—	9300	11012	12000	12000	27,7

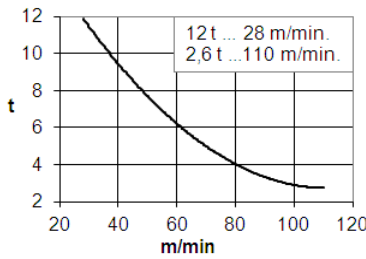
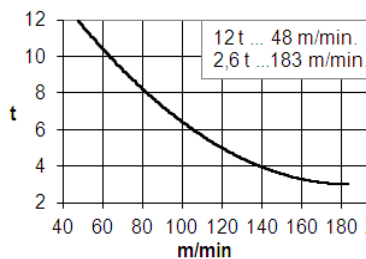
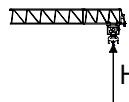
CARACTERISTICAS DE MECANISMOS / MECHANISMS FEATURES / CARACTÉRISTIQUES DES

MÉCANISMES / ХАРАКТЕРИСТИКИ МЕХАНИЗМОВ / MEKANİZMALARIN ÖZELLİKLERİ / الخصائص الآلية

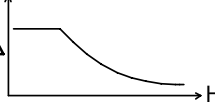
*opcional *optional *en option *опция *opsiyonel *اختياري						
	EC88110VF 65 kW	* EC150185VF 110 kW	TG2020VF 2x7,3 kW	OG2207VF 3x5,5 kW	TC7105VF 5,5 kW	TH2006 15 kW
			°0...20 m/min	0...0,2 0,2...0,35 0,35...0,7 r/min sl/min	6 t 0...105 m/min 12 t 0...52 m/min	0,6 m/min
	H ≤	SR 284		P <sub>TOTAL</sub> (EC88110VF+ OG2207VF + TC7105VF) = 87 kW P <sub>TOTAL</sub> (EC150185VF+ OG2207VF + TC7105VF) = 132 kW		400V 50Hz
						

LASTRES INFERIORES / LOWER BALLASTS

LESTES INFÉRIEURS / НИЖНИЙ БАЛЛАСТ / ALT AĞIRLIK TAŞLARI / ثقل



BRI 10-24	H (m)	66,3	77,5	87
	P (t)	60	72	96
BSRI 8-20-5,6H	H (m)	57,7	65	76,2
	LI=12t P (t)	LI + 48	LI + 60	LI + 108
BSI 8-20-5,6H	H (m)	52,1	59,4	70,6
	LI=12t P (t)	LI + 48	LI + 60	LI + 84
BLI 6-20-5,6H	H (m)	31,3	42,5	59,3
	LI=12t P (t)	LI + 48	LI + 60	LI + 84

H: Altura bajo gancho / Height under hook / Hauteur maximale sous crochet Высота под крюком / Kanca altı yüksekliği / الارتفاع أسفل الخطاف

P: Peso / Weight / Poids / Вес / Ağırlık / وزن

Para alturas intermedias tomar el lastre correspondiente a la altura superior / For intermediate heights take the ballast corresponding to the higher height / Pour les hauteurs intermédiaires, opter pour le lest correspondant à la hauteur immédiatement supérieure / Для промежуточных высот возьмите балласт, соответствующий большей высоте / Orta yükseklikler için daha üst bir yüksekliğe karşılık gelen ağırlığı alınız. / للارتفاعات البينية يرجى استخدام الثقل العائد للارتفاع الأعلى.

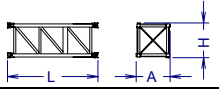
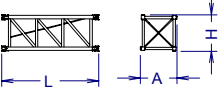
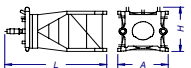
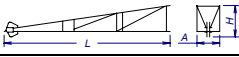
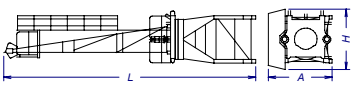
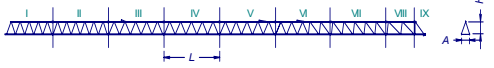

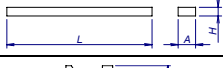
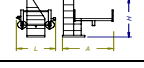
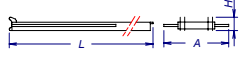
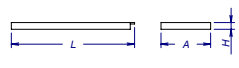
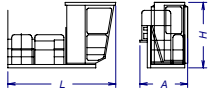
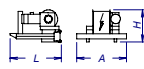
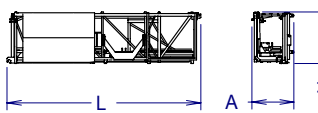
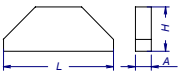
LISTA DE EMBARQUE / PACKING LIST			J300N.2R.A			
LISTE DE COLISAGE / СПИСОК ПОСТАВКИ / ÇEKİ LİSTESİ / قائمة التحميل			L [m]	A [m]	H [m]	P / W [kg]
DENOMINACIÓN / DENOMINATION / DÉSIGNATION / НАЗВАНИЕ / AÇIKLAMA / اسم						
Torre inferior / Lower tower / Tour inférieure / Нижняя башня Alt kule / البرج السفلي	TLI20-5,6		5,886	2,306	2,357	4235
	TSI20-5,6		5,966	2,328	2,390	5390
	TSR120-5,6		5,990	2,257	2,257	6562
	TRID24-5,6		5,990	3,202	3,202	8400
Torre / Tower / Tour Башня / Kule / برج	TL20		4,175	2,201	2,281	2095
	TL20-5,6		5,886	2,306	2,357	2938
	TS20-5,6		5,966	2,328	2,390	3604
	TSR20-5,6		5,990	2,257	2,257	4262
	TSR20-5,6A		5,926	2,388	2,325	3637
	TS20-5,6A		5,978	2,381	2,331	4221
Torre asiento pista + base punta de torre + orientación Slewing table + tower head base + slewing mechanism Tour pivot + base du porte-flèche + mécanisme d'orientation Сиденье площадки + основание верхней секции башни + поворотный механизм Göbek + kule kafa bölümü tabanı+mekanizma برج وحدة الدوارن + قاعدة رأس البرج + آلية الدوران			5,08	2,53	2,27	7390
Punta de torre / Tower head / Porte-flèche верхняя секция башни / kulenin kafa bölümü / رأس البرج			8,19	1,41	1,82	2820
Conjunto asiento pista, punta de torre, orientación Slewing table assembl +, tower head + slewing Groupe pivot + porte-flèche + mécanisme d'orientation Сиденье площадки + верхняя секция башни + поворотный механизм Göbek + kulenin kafa bölümü+mekanizma مجموعة وحدة الدوارن + رأس البرج + آلية الدوران			12,15	3,05	2,48	10750
Tramo de pluma Jib section Tronçon de flèche Секция стрелы Vom bölümü أجزاء الذراع	P17-10R (I)		8,81	1,68	1,99	1740
	P17-2R (II)		10,19	1,60	2,03	2050
	P17-3N (III)		10,19	1,60	2,04	1970
	P17-4N (IV)		10,19	1,60	1,89	1680
	P17-5N (V)		10,19	1,60	1,99	1530
	P17-6R (VI)		10,19	1,60	1,99	1485
	P17-7N (VII)		10,19	1,60	1,89	1165
	P17-8N (VIII)		5,30	1,60	1,89	745
	P17-9N (IX)		2,16	1,60	2,20	420
Polipasto / Hook assembly / Palan / Попуснаст / Kanca takımı / بكرة			1,35	0,3	1,3	400
Tirante sostén pluma / Jib support tie / Tirant de fleche / Растяжка поддержки стрелы / Kol destek bağları / مشد دعامة الذراع	Largo / Long		4,97	0,40	0,74	1605
	Corto / Short		6,02	0,22	0,71	870
Carro / Trolley / Chariot / Грузовая тележка / Şaryo / عربة			2,32	2,42	1,55	570
Contrapluma con plataformas / Counterjib with platforms Contre-flèche avec plateformes / Противовесная консоль с платформами / Platformlu kuyruk / المصعد المقابل مع المنصة /			12,10	2,76	0,62	3085
Prolongación contrapluma con plataforma / Counterjib extension with platform Prolongement contre-flèche avec plateforme / Удлинение противовесной консоли с платформой / Kuyruk platformla uzatılması / امتداد الذراع المعاكس / مع الممرات			8,30	1,91	0,58	1925
Plataforma y cabina / Platform and cabin / Plateforme et cabine منصة وكابينة / Platform ve kabin /			3,69	1,63	2,25	850
Soporte y elevación (sin cable) / Support and hoisting (without rope) / Support et levage (sans câble) / Опора и подъем (без троса) / Destek ve vinç kulesi (kabloşuz) / دعم ورفع (بدون كابل)	EC 88110 VF		3,03	2,3	2,12	3900
Transporte torre de montaje/ Jacking cage transport / Transport de tour de montage / Транспортировка монтажной башни / Kaldırma kafesinin taşınması / نقل برج التركيب	TM20L-5,6		9,550	2,070	2,520	5,690
Lastre / Ballast / Lest / Балласт / Alt ağırlık taşları / نقل			3,80	0,58	1,5	6000



JASO EQUIPOS DE OBRAS Y CONSTRUCCIONES, S.L.



FEM 1005 - C25

Reservado el derecho a modificaciones sin previo aviso. Declinamos toda responsabilidad derivada de la información proporcionada / Subject to modification, without previous warning. This information is supplied without liability / L'entreprise se réserve le droit de procéder à des modifications sans préavis. Nous déclinons toute responsabilité quant aux informations fournies / Мы оставляем за собой право на внесение изменений без предварительного уведомления. Мы снимаем с себя любую ответственность в отношении предоставленной информации / Önceden bildirilmeksizin değiştirilme hakkı saklıdır. Verilen

Fecha / Date: 15-03-2013

bilgiler için hiçbir sorumluluk kabul etmemekteyiz / حقوق التغيير محفوظة دون إشعار مسبق دون أدنى مسؤولية عن المعلومات المقدمة

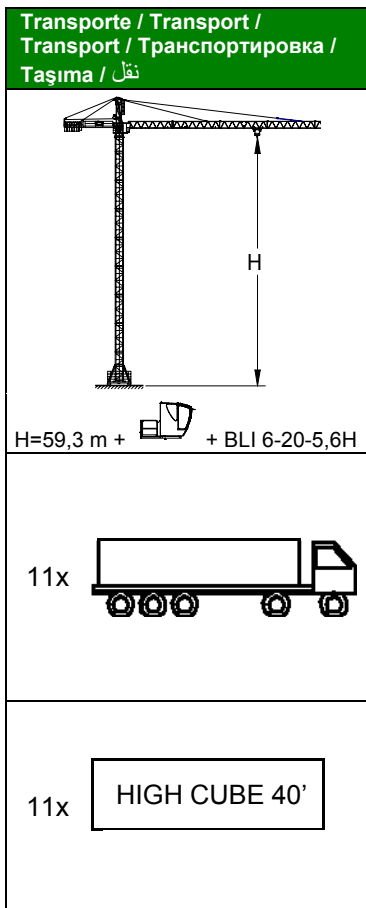
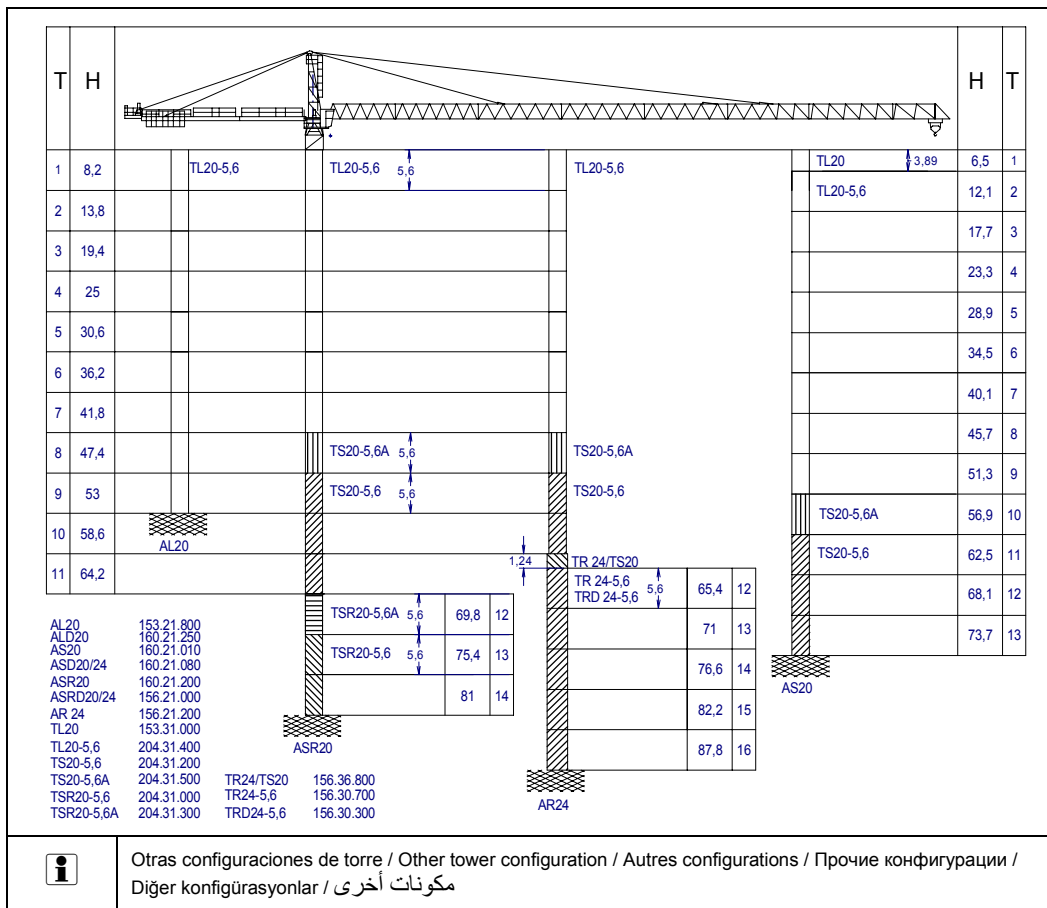

TREPADO / CLIMBING / TÉLESCOPAGE / ЛЕСТНИЦА / TIRMANMA / التسلق

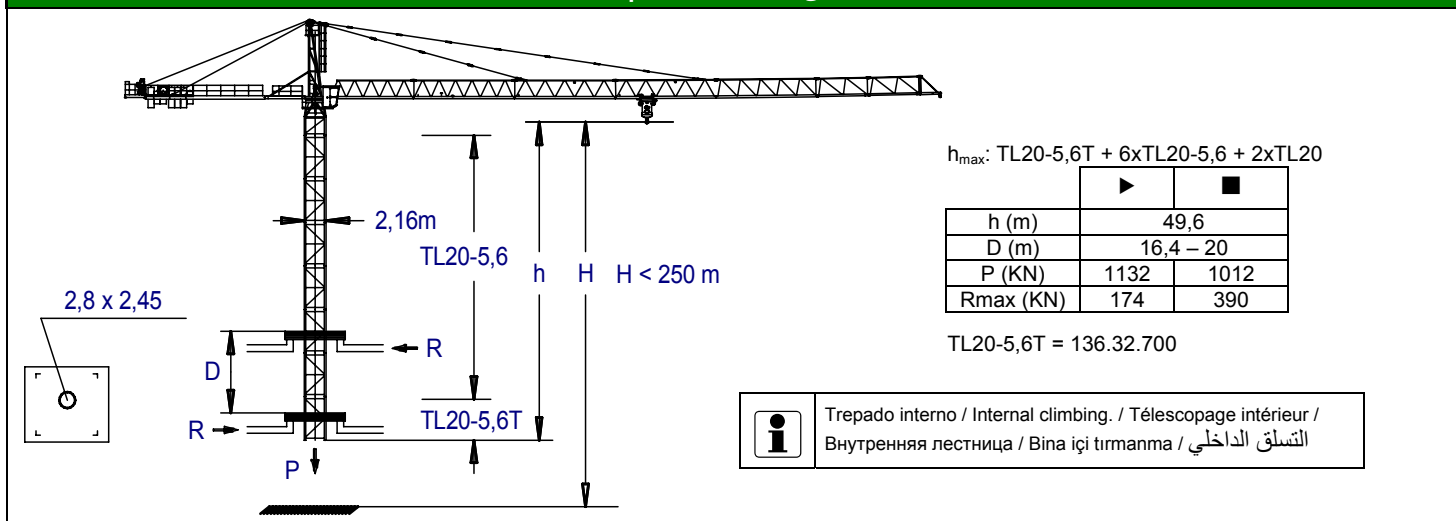

Wiento fuera de servicio / Out of service wind / Vitesse du vent hors service / Ветровая нагрузка в покое / Rüzgar devre dışı / الريح خارج الخدمة

- Consultar / Consult / Nous consulter / Консультируйтесь / Danışınız / الرجوع إلى
- En servicio / In service / En service / В работе / Devrede / في الخدمة
- Fuera de servicio / Out of service / Hors service / В покое / Devre dışı / خارج الخدمة



JASO EQUIPOS DE OBRAS Y CONSTRUCCIONES, S.L.

Ctra./Rd. Madrid - Irún Km. 415  
20.213 IDIAZABAL [Gipuzkoa]  
ESPAÑA / SPAIN  
P.O. Box, 23 - 20.200 BEASAIN

Tel. +34 943 - 18 70 00  
Fax. +34 943 - 18 70 20  
E-mail: jaso@jaso.com  
http://www.jaso.com

Fecha / Date: 15-03-2013



FEM 1005 - C25

DELEGACION / DELEGATION

Reservado el derecho a modificaciones sin previo aviso. Declinamos toda responsabilidad derivada de la información proporcionada / Subject to modification, without previous warning. This information is supplied without liability / L'entreprise se réserve le droit de procéder à des modifications sans préavis. Nous déclinons toute responsabilité quant aux informations fournies / Мы оставляем за собой право на внесение изменений без предварительного уведомления. Мы снимаем с себя любую ответственность в отношении предоставленной информации / Önceden bildirilmeksizin değiştirilme hakkı saklıdır. Verilen bilgiler için hiçbir sorumluluk kabul etmemekteyiz / حقوق التغيير محفوظة دون إشعار مسبق. بدون أدنى مسؤولية عن المعلومات المقدمة